

SIZE
A

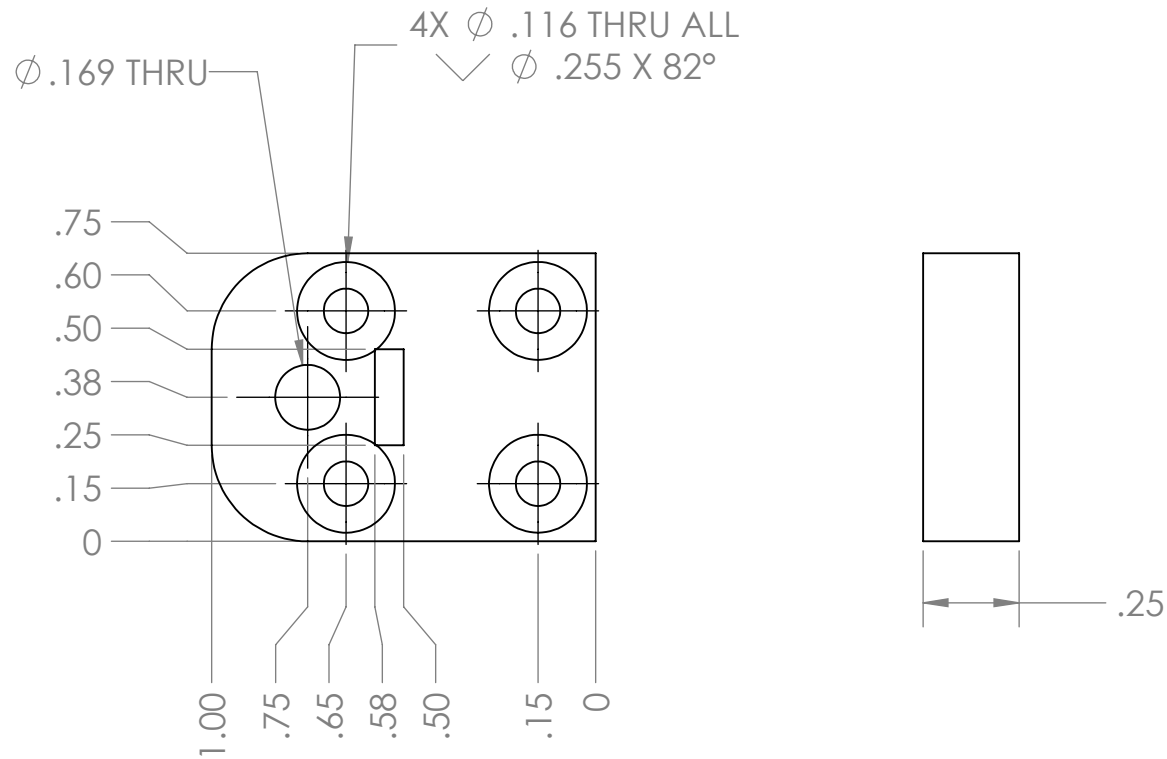

REMOVE BURRS & SHARP EDGES

UNLESS OTHERWISE SPECIFIED:
DIMENSIONS ARE IN INCHES

TOLERANCES:
 FRACTIONAL $\pm 1/32"$
 ANGULAR: MACH $\pm 2^\circ$ BEND: $\pm 1/16"$
 TWO PLACE DECIMAL $\pm 0.020"$
 THREE PLACE DECIMAL $\pm 0.005"$

BELT MOUNT UPPER, SADDLE

DESCRIPTION

PART NO.

GROUP

ENGINEER

SHAWN WRIGHT

DRAWN BY

DATE

MATERIAL WEIGHT

2:1

SCALE REV.

H:\ME_450\Linear Book Scanner\Saddle\

FILE PATH