

SIZE  
**A**

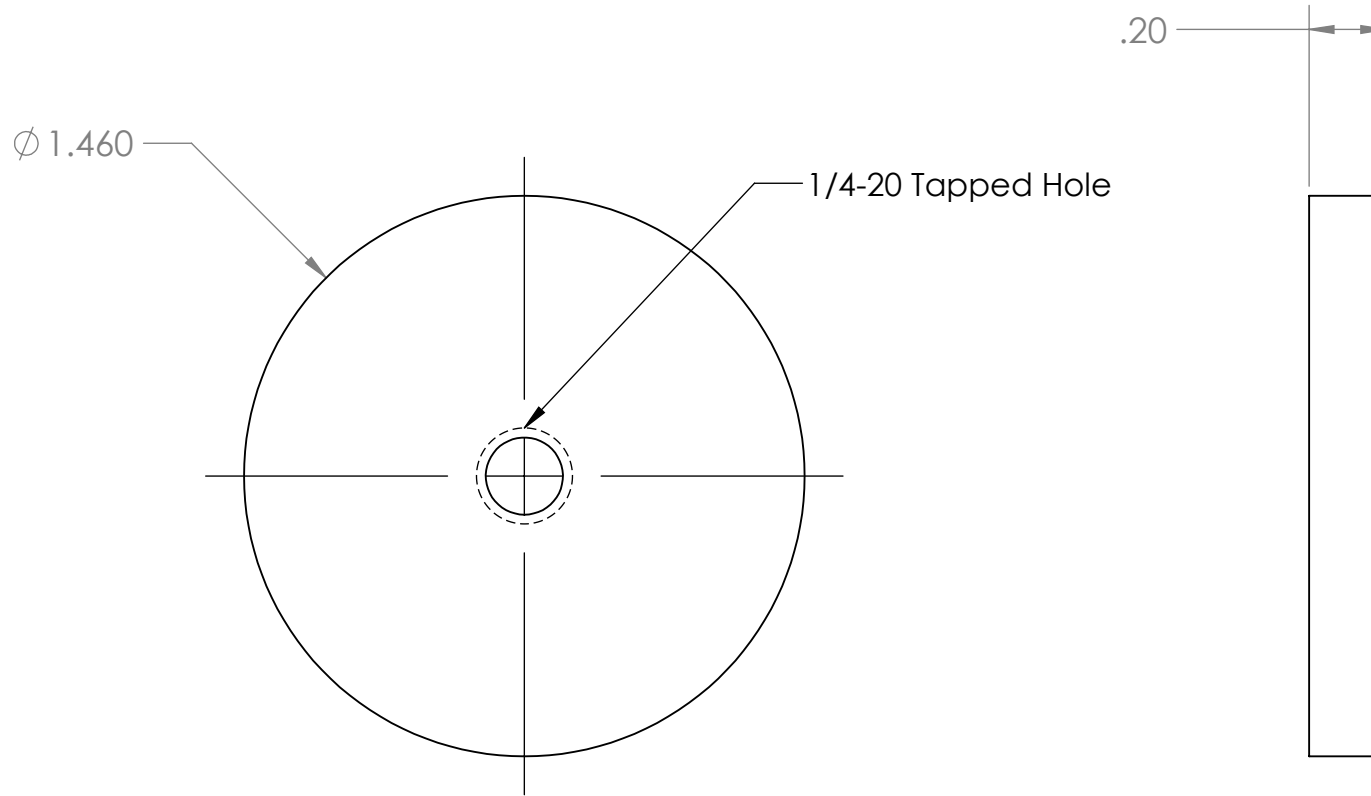

REMOVE BURRS & SHARP EDGES

UNLESS OTHERWISE SPECIFIED:  
DIMENSIONS ARE IN INCHES

TOLERANCES:  
 FRACTIONAL  $\pm 1/32"$   
 ANGULAR: MACH  $\pm 2^\circ$  BEND:  $\pm 1/16"$   
 TWO PLACE DECIMAL  $\pm 0.020"$   
 THREE PLACE DECIMAL  $\pm 0.005"$

## INSIDE TUBE CAP, VACUUM TUBE

DESCRIPTION

PART NO.	GROUP		
ENGINEER	SHAWN WRIGHT	DRAWN BY	DATE
MATERIAL	WEIGHT	SCALE	REV.
H:\ME_450\Linear Book Scanner\Vacuum Tube\			FILE PATH