

SIZE
A

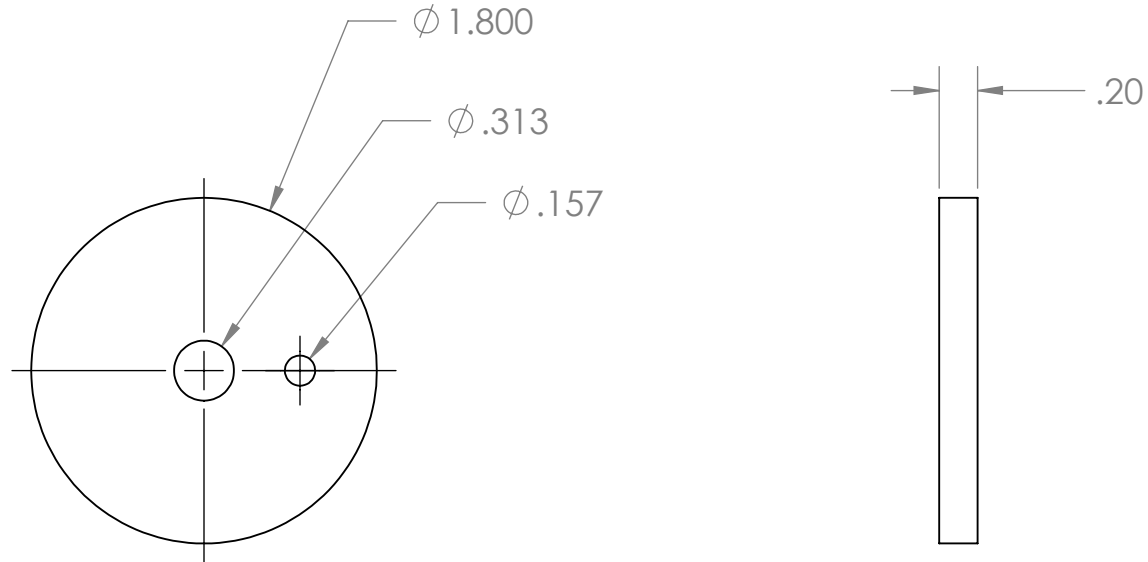

REMOVE BURRS & SHARP EDGES

UNLESS OTHERWISE SPECIFIED:
DIMENSIONS ARE IN INCHES

TOLERANCES:
 FRACTIONAL $\pm 1/32$ "
 ANGULAR: MACH $\pm 2^\circ$ BEND: $\pm 1/16$ "
 TWO PLACE DECIMAL ± 0.020 "
 THREE PLACE DECIMAL ± 0.005 "

OUTSIDE TUBE CAP, VACUUM TUBE

DESCRIPTION

PART NO.	GROUP		
ENGINEER	SHAWN WRIGHT	DRAWN BY	DATE
MATERIAL	WEIGHT	1:1	SCALE REV.
H:\ME_450\Linear Book Scanner\Vacuum Tube\			FILE PATH